

How to get it right the first time...

FITTING INSTRUCTIONS: INSTALLING YOUR NEW EXEDY CLUTCH

Failure to observe these instructions when fitting your Exedy Clutch will void any warranty.

1. Getting it right the first time. It is vital to diagnose the cause of clutch malfunction before clutch replacement, i.e. check hydraulic system - bearing free travel - clutch cable, oil leaks and check for any signs of red dust when old clutch is being removed. Any or all of these problems must be corrected before installing a new clutch.
2. Ensure clutch supplied is correct for the application. If you're unsure, consult your Exedy Clutch Catalog or your supplier, as fitting a clutch to the wrong application will void the warranty.
3. Flywheel must be replaced or machined as shown below (Fig 2. max 0.03 in.) or warranty will be void and check spigot bearing or the pilot bush and replace if necessary. Please note pilot bush noises are more apparent when the engine and transmission systems are cold (i.e. in the mornings).
4. Before fitting, check the clutch for any shipping damage. Next clean the gear box main drive shaft splines, then check that clutch disc slides freely on the shaft. Lightly grease the shaft splines with high melting point grease. Always ensure bell housing is degreased and is free of any dust and that fibers from the worn clutch are removed. If the clutch is a large size pull type clutch check the ID of the bearing head for correct spline size before installation. Lack of lubrication/dry splines will cause failure to disengage gears and also cause clutch drag. Never over lubricate / grease the spline of your clutch disc as grease will splatter during rotation of the engine and clutch. Contamination – grease/oil on the clutch disc friction material will cause the clutch to slip.
5. Check clutch release fork for cracks, check the clutch cable for stretch signs and check the release bearing guide tube for any wear. Always lightly grease the outside diameter of the tube. This will allow smooth sliding of the bearing carrier. Always check bearing on clutch release fork after installing the bearing on it. Move the fork forwards and backwards i.e. in both directions, to ensure bearing is secure and does not fall on any part (clutch fork or bell housing) before refitting gear box.
6. Place the clutch cover pressure plate assembly over the clutch disc, after checking that the disc is the right way around and the hub section of the disc does not fall on the casting of the clutch cover assembly or the flywheel. A suitable clutch aligning tool will ensure correct alignment, assist in ease of installation and avoid spline damage. (Burr on splines are a major cause of difficult gear disengagement). Ensure pressure plate dowels are aligned to the cover. Tighten bolts in a diagonal pattern and never use air tools to install a clutch cover assembly. Torquing down bolts in an uneven pattern in some instances could cause the lever strut to dislodge itself from the pressure plate casting.
7. When the pressure plate has been torqued down securely to the flywheel, ensure that the diaphragm tips (in the case of a lever type cover assembly, the release lever tips) are in a parallel or slightly upward position (see Fig 3) and do not go over center of the parallel position.
8. Refit gear box, taking care not to bend the clutch disc. Never hang the gear box off the clutch disc or use any force to align gear box shaft.
9. Check all bell housing dowels are in correct position and tighten bell housing bolts. Ensure there is no dirt or foreign material between the mating surfaces of the engine and the bell housing.
10. Perform any clutch adjustments to vehicle manufacturer's specifications and always reset the clutch master cylinder push rod to obtain comfortable pedal release position (clutch taking up as close as possible to the floor prevents clutch shudder and in most cases preferred by vehicle drivers). Keep in mind that the diaphragm tip position has changed with the installation of the new clutch.
11. Always check the clutch cable if you are unable to obtain disengagement when a new clutch is fitted. Start off your checking process by replacing the cable. If it is a hydraulic clutch start by checking the clutch master cylinder and the clutch slave cylinder, ensuring there is no air in the system. This is essential to obtain maximum travel for disengagement.
12. Road test vehicle and never abuse a newly fitted clutch. Allow 750 mi break in and always adjust free travel on your new clutch at 750 mi and 1500 miles. Thereafter, adjust at every 10,000 miles

WARNING: Do not use EXEDY clutches in any situation where engine RPM's may exceed manufacturer's specifications - a pressure plate could explode unexpectedly causing serious injury or death to vehicle occupants and bystanders. Clutch cover and bell housing will not protect against exploding pressure plates. Refer to the Application Catalogue for correct fit.

For performance / sport applications always use an Exedy sports replacement clutch.

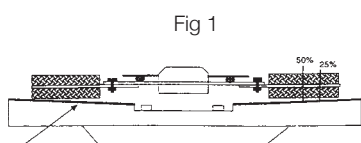

Fig 1
Beveled out surface might look smooth but uneven

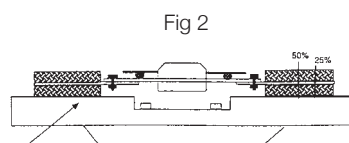
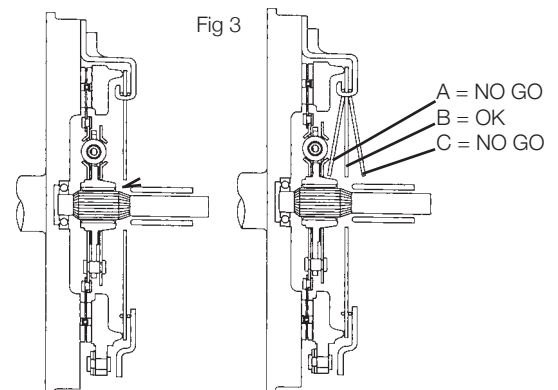

Fig 2
Good flat machined surface



1-800-346-6091



4-15-08

General Misalignment Issues / Tips

1. Check for a warped alloy bell housing
2. Examine tubular dowel pins for damage during fitting of bell housing or for missing dowel pins.
3. Examine gearbox quill/gearbox main drive nose cone/bearing slide: Excessive wear can cause bearing to come in contact with the cover assembly diaphragm unevenly while actuating the clutch.
4. Ensure the proper mating of bell housing to motor, and crankshaft to flywheel. These may not mate properly due to debris, grease or other parts in the way of the mating surfaces.
5. Examine all bearings/bushings for excessive wear, replace if necessary.
6. Replacement engines and gearboxes may have missing dowel pins. Ensure that you remove pins from your product when you send your core for remanufacture, and refit or replace them when installing new clutch.

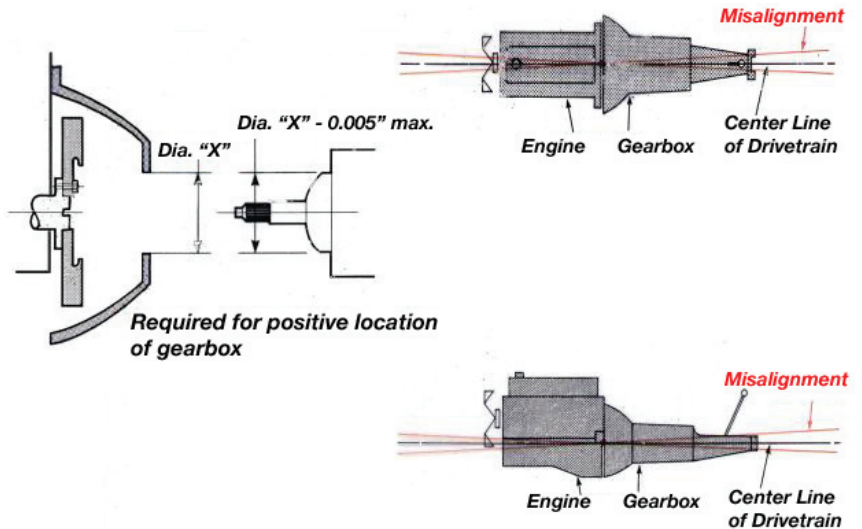

Hanging the Gearbox

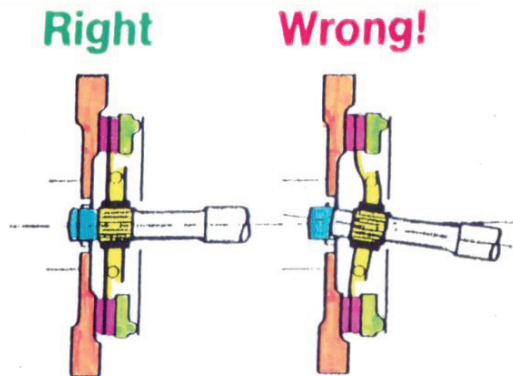

DON'T HANG THE RESULTS ON US

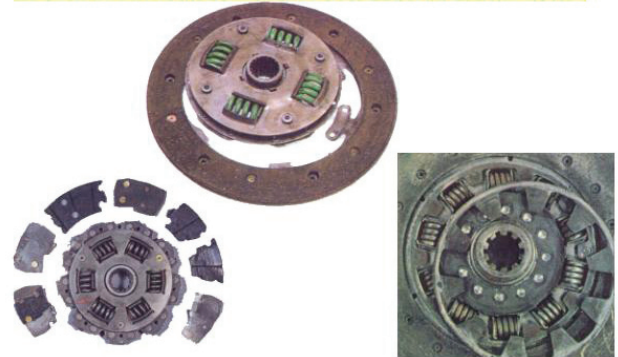

Examples of Common Warranty Exclusions

